

# FIREGUARD RECESSED PENDENT SPRINKLER HEAD

## Product Data Sheet

Website item: Sprinkler Head Recessed Pendent

**FIRE PROTECTION SPRINKLER SYSTEMS**

---

Relevant datasheet pages attached after this cover page.



## Automatic Sprinklers

### UPRIGHT SPRINKLERS AND PENDENT SPRINKLERS

MODEL: **FA003U** **FA004U** **FA005P** **FA006P**

**STANDARD SPRAY, STANDARD QUICK RESPONSE, 5 3 mm BULB TYPE, K5.6, 1/2" CONNECTING THREAD**

#### GENERAL DESCRIPTION

The FA003U/FA004U Standard/Quick Response Upright and FA005P/FA006P Standard/Quick Response Pendent Sprinklers (Ref. Figure A) are automatic sprinklers of the frangible bulb type. They are "standard/quick response – standard orifice spray sprinkler" intended for use in fire sprinkler systems designed in accordance with the standard installation rules recognized by the applicable Listing or Approval agency (e.g., UL Listing is based on NFPA 13 requirements). The Upright, Pendent Sprinklers all produce a hemispherical water distribution pattern below the deflector.

#### SPRINKLER OPERATION

During a fire conditions, the thermal-sensitive liquid in the glass bulb expands, causing the bulb to shatter, releasing the button and spring seal assembly. Water flowing through the sprinkler orifice strikes the sprinkler deflector, forming a uniform spray pattern to extinguish or control the fire.

#### COVERAGE

For coverage area and sprinkler placement, refer to NFPA13 standards.

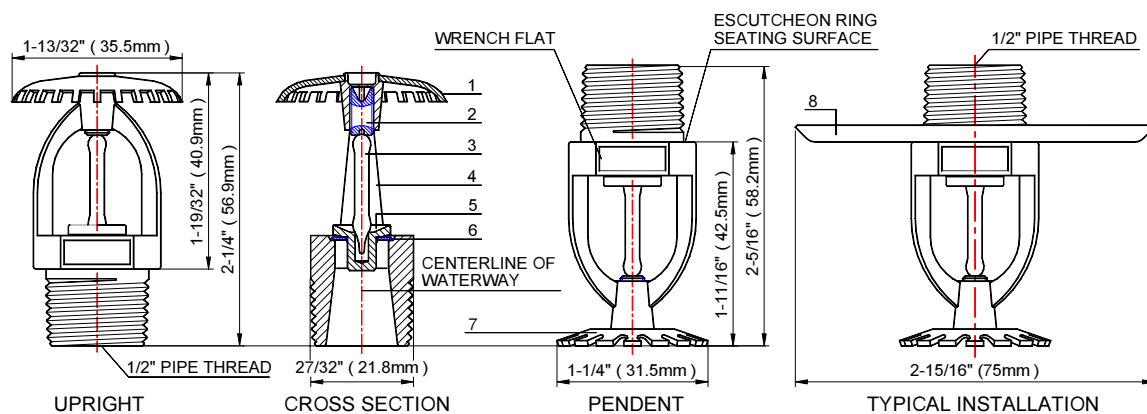

1.SSU DEFLECTOR 2.SET SCREW 3.GLASS BULB 4.FRAME 5.BUTTON 6.SPRING SEAL 7.SSP DEFLECTOR 8.STANDARD ESCUTCHEON

FIGURE A : MODEL FA003U/FA004U UPRIGHT & MODEL FA005P/FA006P PENDENT SPRINKLERS

#### TECHNICAL SPECIFICATIONS

Model & Sprinkler I.D. No. <sup>1</sup>	FA003U	FA004U	FA005P	FA006P
Style	Upright		Pendent	
Response & Bulb Nominal Dia.	Standard Response, Ø5mm	Quick Response, Ø3mm	Standard Response, Ø5mm	Quick Response, Ø3mm
Temp. Classification	Ordinary	Ordinary	Intermediate	Intermediate
Nominal Temp. Rating	175 79	155 68	175 79	200 93
Nominal Temp. Rating	155 68			

# Automatic Sprinklers

Max. Ambient Temp. Allowed <sup>2</sup>	115 46	135 57	155 68	180 82
Max. Recommended Ambient Temp. <sup>3</sup>	100 38	100 38	150 65	150 65
Glass Bulb Color <sup>4</sup>	Orange	Red	Yellow	Green
Thread Size [Optional]	NPT1/2 or R1 2 <sup>5</sup>			
Nominal Orifice Size	1/2 Inch			
Nominal K-Factor <sup>1</sup>	5.6 (U.S.) 80 (metric)			
Max. Working Pressure	175 psig 1.2 MPa (12 bar)			
Factory Hydrostatic Test	100% @ 500psig (3.4 MPa)			
Min. Operating Pressure	7 psig 0.048 MPa (0.48 bar)			
Sprinkler Finish [Optional]	Natural Brass or Chrome Plated			
Escutcheon Finish	Chrome Plated or Color Coated In Any Color			
Listings and Approvals <sup>6</sup>	UL(United States)			
<b>Footnotes:</b>				
<sup>1</sup> Sprinkler I.D. Nos. and nominal U.S. K-factors provided in accordance with the 2002 edition of NFPA 13.				
<sup>2</sup> Based on National Fire Prevention and Control Administration Contract No. 7-34860.				
<sup>3</sup> Based on NFPA 13. Other limits may apply depending on fire loading, sprinkler location, and other requirements of the Authority Having Jurisdiction. Refer to specific installation standards.				
<sup>4</sup> The temperature rating is stamped on the deflector or adjacent to orifice seat on frame.				
<sup>5</sup> The pipe thread connections accord with ISO7/1.				
<sup>6</sup> This table shows the listings and approvals available at the time of printing. Check with the manufacturer for any additional approvals.				
<sup>7</sup> UL Listed for both Light-Hazard and Ordinary-Hazard occupancies.				

## SPRINKLER MATERIALS

Frame	Bronze Forging UNS-C87400
Deflector	Brass UNS-28000
Glass Bulb	Glass with Glycerin Solution, JOB <sup>®</sup> G5 for FAU003/ FAP005 JOB <sup>®</sup> F3 for FAU004/ FAP006
Set Screw	Brass UNS-28000
Button	Brass UNS-28000
Spring	Stainless Steel
Seal	Teflon <sup>®</sup> Tape
Standard Escutcheon (Type E-0)	Cold Rolled Steel

## ACCESSORIES

<b>Installation Wrench</b>	
Type	T-1

## DISCHARGE COEFFICIENT

Model FA003U/FA004U Upright and Model FA005P/FA006P Pendent Sprinklers are rated for use

at a maximum service pressure of 175 psig (12 bar).

The nominal discharge curve plotted in Figure B represents the flow "Q" in GPM (LPM) as determined by the following formula:

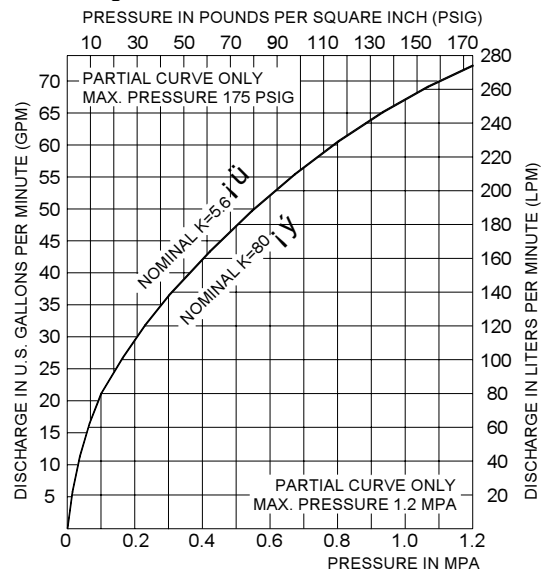

**FIGURE B : NOMINAL DISCHARGE CURVE**



## Automatic Sprinklers

---

$$Q = K P^{0.5}$$

Where:

*Q* — Flow, LPM (GPM)

*K* — Discharge Coefficient, *K* = 5.6 (80)

*P* — Discharge Pressure, psig (bar)

Listing standards permit the actual value of “K” to vary from 5.3 to 5.8 (76,4 to 83,6); however, for hydraulic calculations, a K-factor of 5.6 (80,7) is to be applied.

# Automatic Sprinklers

## WARNING

The Model FA003U/FA004U Upright Sprinklers and Model FA005P/FA006P Pendant Sprinklers described herein must be installed and maintained in compliance with this document, as well as applicable standards of the National Fire Protection Association, in addition to the standards of any other authorities having jurisdiction. Failure to do so may impair the integrity of these devices.

The owner is responsible for maintaining their fire protection system and devices in proper operating condition. The installing contractor or manufacturer should be contacted relative to any questions.

## INSTALLATION

### NOTES

Do not install any bulb type sprinkler if the bulb is cracked or there is a loss of liquid from the bulb. With the sprinkler held horizontal, a small air bubble should be present. The diameter of the air bubble is approximately 1/16" (1.6 mm) for the 135°F/57°C to 3/32" (2.4 mm) for the 286°F/141°C rating. (At higher ambient temperatures, the bubble may be barely perceptible for the lower temperature ratings.)

The Model FA003U/FA004U Upright Sprinklers and Model FA005P/FA006P Pendant Sprinklers must be installed in accordance with the following instructions.

1. Prior to installing the sprinklers, if applicable, verify that the face of the sprinkler fitting is within the proper range of distance, which can be accommodated by the type of escutcheon being used.
2. With pipe thread sealant applied to the pipe threads or teflon tape to the male end only and after installing standard escutcheon, over the sprinkler threads, hand tighten the sprinkler into the sprinkler fitting.
3. Refer to Figure D and select the appropriate Sprinkler Wrench for tightening the sprinkler

into the sprinkler fitting.

### NOTES

A leak tight 1/2" pipe thread sprinkler joint should be obtained with a torque of 7 to 14 ft.lbs. (9.5 to 19.0 Nm). A maximum of 21 ft.lbs. (28.5 Nm) of torque is to be used to install the sprinkler. Higher levels of torque may distort the sprinkler inlet with consequent leakage or impairment of the sprinkler.

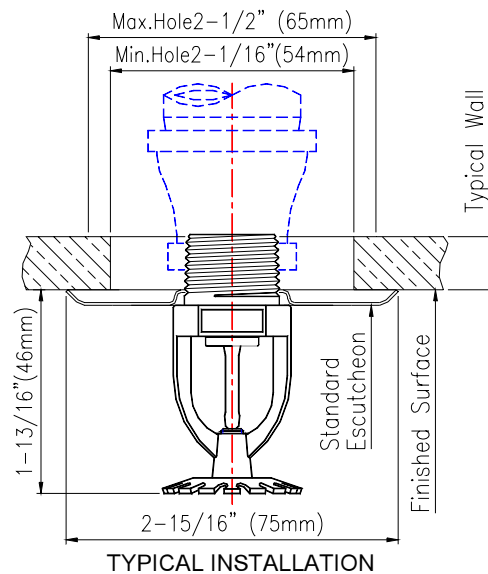

FIGURE C : MODEL FAP005/FAP006 PENDENT SPRINKLER INSTALLED WITH A STANDARD ESCUTCHEON

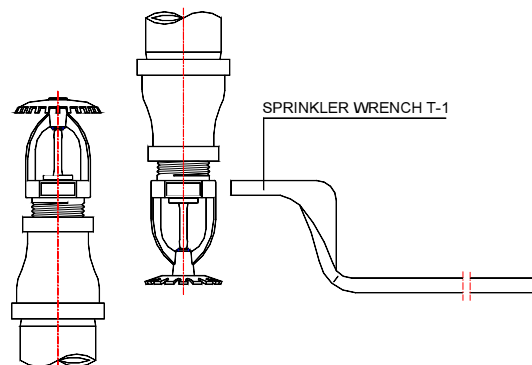

FIGURE D : SPRINKLER WRENCH SELECTION & USE

**Push on the Sprinkler Wrench, while it is being**



## Automatic Sprinklers

turned, to ensure that the Wrench recess stays fully engaged with the sprinkler wrench flats.

Carefully remove the Sprinkler Wrench by disengaging it from the sprinkler wrench flats, and then lowering it down over the sprinkler deflector.

### CARE AND MAINTENANCE

Automatic sprinklers must never be shipped or stored where their temperatures will exceed 100°F/38°C and they must never be painted, plated, coated or otherwise altered after leaving the factory. Modified sprinklers must be replaced. Sprinklers that have been exposed to corrosive products of combustion, but have not operated, should be replaced if they cannot be completely cleaned by wiping the sprinkler with a cloth or by brushing it with a soft bristle brush.

Care must be exercised to avoid damage to the sprinklers — both before and after installation. Sprinklers damaged by dropping, striking, wrench twist/slippage, or the like, must be replaced. Also, replace any sprinkler that has a cracked bulb or that has lost liquid from its bulb (ref. Installation Section Note).

### NOTES

*Absence of an escutcheon, which is used to cover a clearance hole, may delay the time to sprinkler operation in a fire situation.*

*Before closing a fire protection system control valve for maintenance work on the fire protection system, which it controls, permission to shut down the affected fire protection system must be obtained from the proper authorities and all personnel who may be affected by this action must be notified.*

It is recommended that automatic sprinkler systems be inspected quarterly by a qualified Inspection Service.

### WARRANTY

Seller warrants for a period of one year from the date of shipment (warranty period) that the products furnished hereunder will be free from defects in material and workmanship.

For further details on Warranty, see Price List.

### ORDERING PROCEDURE

A Product Symbol Number (PSN) shall be specified when ordering sprinklers. And it is suggested that a color chip be provided when ordering special color

coated Escutcheons. Otherwise, responsibility for duplication cannot be accepted.

Contact your local distributor for availability.

### Sprinkler Assemblies:

Specify: 1/2" orifice, (specify temperature rating), Model FA003U/FA004U Upright Sprinkler and Model FA005P/FA006P Pendent sprinklers with (specify type of finish), PSN (specify as follows).

### PSN 5 -- X1 -- X2 -- X3 -- X4

X1	Sprinkler Model
003	S.R. Upright
004	Q.R. Upright
005	S.R. Pendent
006	Q.R. Pendent
X2	Sprinkler Finish
1	Natural Brass
2	Chrome Plated
X3	Thread Size
1	NPT1/2
2	R1 2 per ISO 7/1
X4	Nominal Temperature Rating
135	135 57
155	155 68
175	175 79
200	200 93

### Recessed Escutcheon:

Specify: 1/2" Model (specify) Standard Escutcheon with (specify finish), PSN (specify).

1/2" E-0 Chrome . . . . . PSN 5-E0-1-1  
 1/2" E-0 White . . . . . PSN 5-E0-1-2

### Sprinkler Wrench:

Specify: Model T-1 Sprinkler Wrench, PSN 5-T1.

### WEIGHT

The nominal weights are as follows.

1/2" Orifice Model FAU003/FAU004 Upright	2.8 ozs. (80 g)
1/2" Orifice Model FAP005/FAP006 Pendent	2.8 ozs. (80 g)
E-0 Standard Escutcheon	0.6 ozs. (18 g)
Sprinkler Wrench	18 ozs. (510 g)