



Valves

FGT1000 TEST AND DRAIN VALVE



Fireguard Test and Drain valve with an integral sight glass assembly, provides a simplified means for testing of waterflow alarm devices and draining of feed mains. Test and Drain valve is a 300 PSI rated single handle ball valve that was specifically designed to provide both the test function and the express drain function required for a wet fire sprinkler system. It include tamper resistant test orifice and sight glass for maximum visibility when operated.

Technical Specification:

- * Sizes 1", 1 1/4", 1 1/2", 2"
- * K factor: 5.6 & 8.0
- * Brass Body with three position (OFF / TEST / DRAIN)
- * Pressure rating 300 PSI
- * Operating temperature range - 10°C to 120°C
- * Tamper resistant test orifice
- * UL Listed

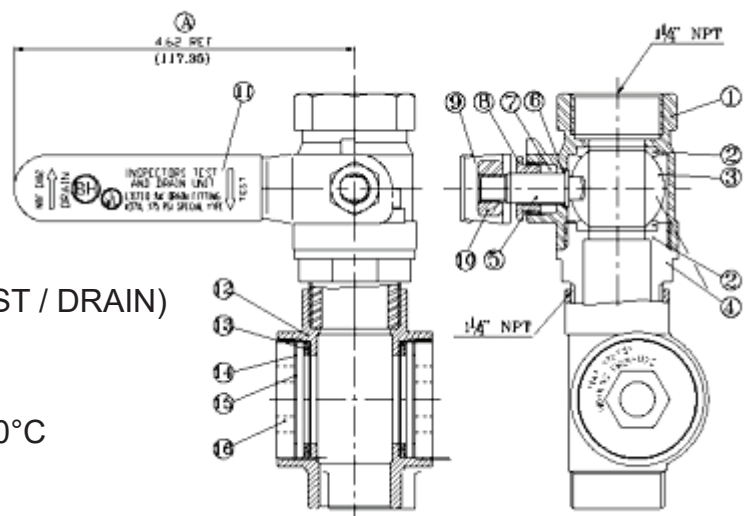

FIRE PROTECTION VALVES